



### ELITE TRACK HYDRO CIRCAL®

The Elite Hydro CIRCAL®, found in our curtain track portfolio, is made of minimum 75% recycled aluminium. The track is manufactured locally in Vetlanda (Sweden) with low emissions during the process. The appearance is identical to the original Luxaflex® Elite track, used for most curtain suspensions, from light to medium heavy. Easy mounting with snap function. Used with a variety of different gliders, both regular and glider on cord.

- Material: aluminium
- Color: white (RAL 9003)
- Manufacture: produced and extruded by Hydro, Sweden
- Operation: manually
- Length: 6000 mm without joint
- Mounting: ceiling, wall, niche and pendant
- Bending: angle and round
- Textile weight: medium (max. 5 kg per 6 m track)
- Silicone treated
- Optional: hole punched track for easier insertion and removal of the gliders

## TECHNICAL INFORMATION

### Profile

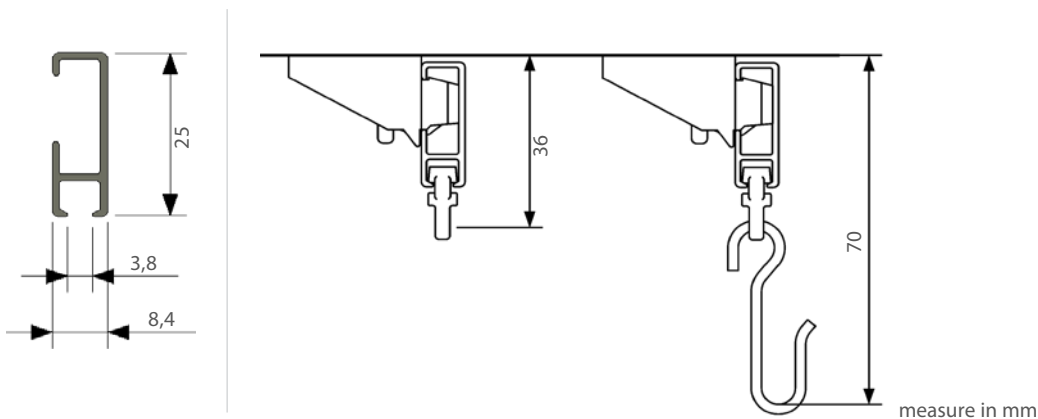

### Mounting

#### CEILING

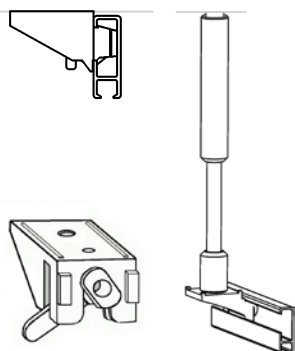

#### WALL

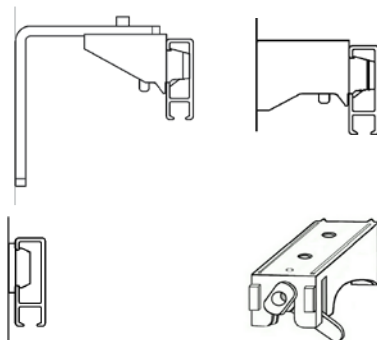

#### ASSEMBLY

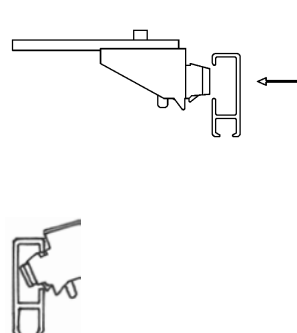

Distance between brackets max 1000 mm.

Extra holders/brackets are recommended where the curtain is parked, when not in use.

Recommended distance if holders are used together with brackets:

- 1000 mm with 50 mm holder
- 800 mm with 100 mm holder
- 600 mm with 150 mm holder
- 500 mm with 200 mm holder

#### Mounting options.

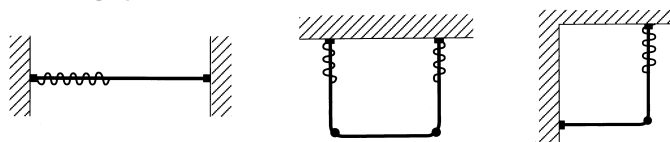

### Bending

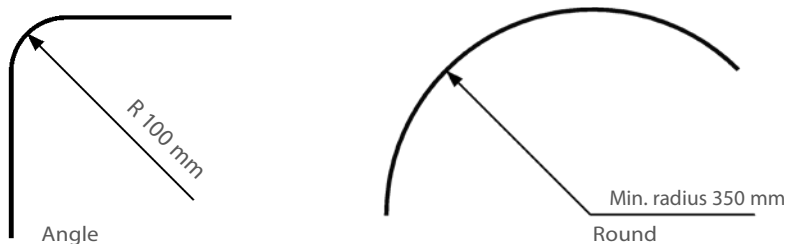

The track can be bent into complicated shapes, even in combinations of angle and round bending. Important! Front and back need to be specified on drawing/order. Contact Customer Service for more detailed information.